

Pompa Freno Radiale CNC PRS Ø17x17/18/19
 Billet Brake Master Cylinder PRS Ø17x17/18/19
 Bomba de freno CNC PRS Ø17x17/18/19

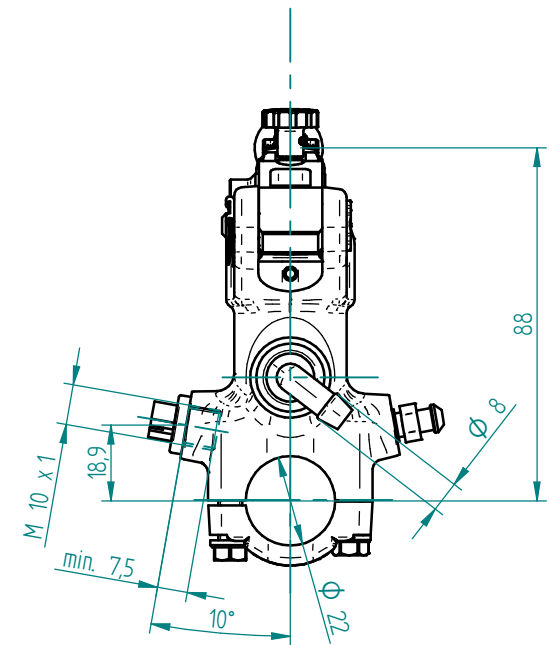
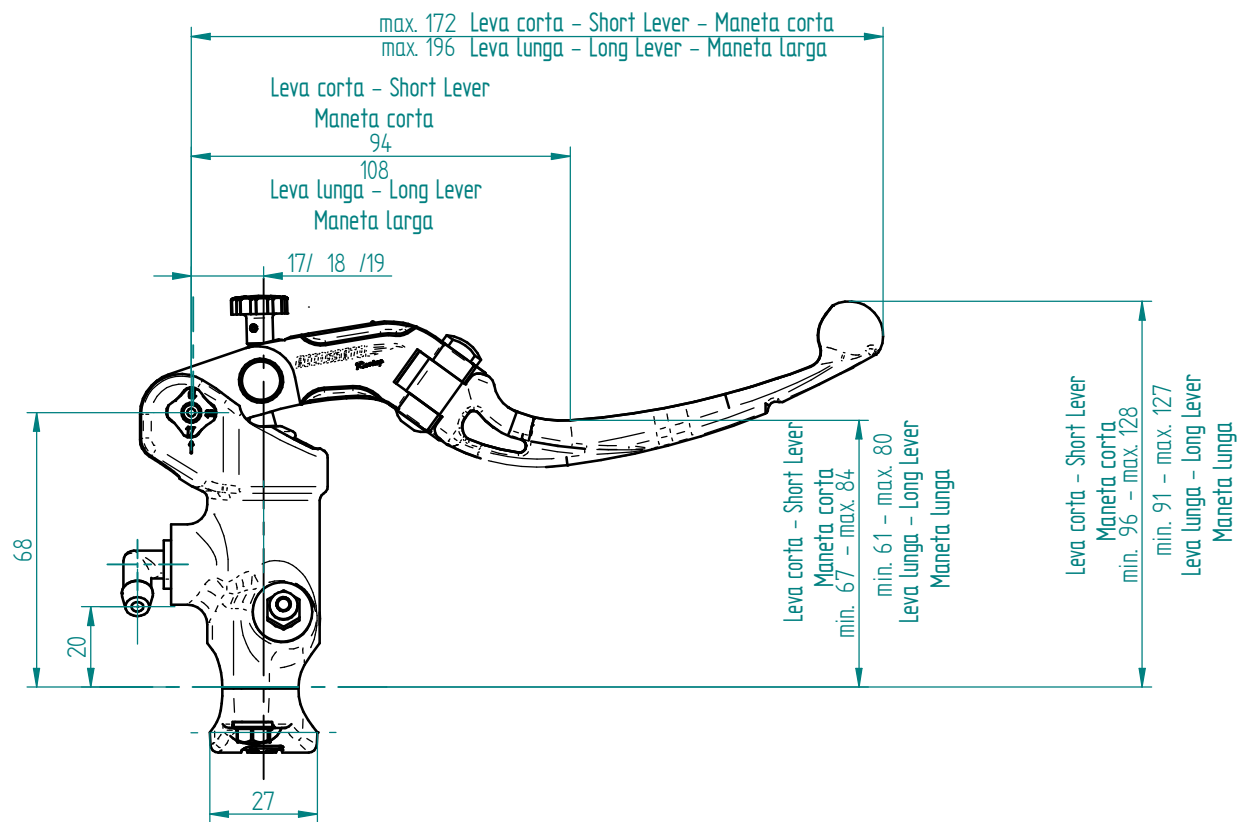

Specifiche tecniche : Technical details :

lavorazione dal pieno CNC	Fully billet machined
Diametro Pistone: 17 mm	Piston Diameter: 17 mm
Interasse: 17/18/19 mm	Distance: 17/18/19 mm
Tipo Leva: snodata	Level: folding
Viteria: acciaio zincato	Screws: stainless steel
Cavallotto: disassato	Offset handlebar clamp
Misura attacco tubi freno: M10x1	Brake hose screw pitch: M10x1
Serbatoio Olio: non incluso	Oil tank: not included
Olio consigliato: DOT4	Recommended braking fluid: DOT4

Especificaciones tecnicas :

mecanizado de solidos CNC
Diametro del piston: 17 mm
Distancia entre ejes: 17/18/19 mm
Tipo de maneta: abatible
Tornillos: acero galvanizado
Perno en U: desplazado
Tamano de conexion de la manguera de freno: M10x1
Tanque de aceite: no incluido
Aceite recomendado: DOT4

ALCOSSATO
CY080